

INTRODUCTION

To the owner or user: The service manual you are reading is intended to provide you, and the maintenance or service technician, with the information needed to install, start up, clean, maintain, and service this ice system.

The NSE654 is a complete ice system that produces and stores nugget ice.

It features: front service for the condenser, control box, and water reservoir; an electronic circuit for monitoring ice and water level; a thermostatic expansion valve; and HP62 as the refrigerant.

Table of Contents

FOR THE INSTALLER	Page 2
FOR THE INSTALLER: Environmental Limitations	Page 3
FOR THE PLUMBER	Page 4
FOR THE ELECTRICIAN	Page 5
FOR THE INSTALLER	Page 6
START UP	Page 7
COMPONENT DESCRIPTION	Page 8
COMPONENT DESCRIPTION	Page 9
COMPONENT DESCRIPTION: Control Box	Page 10
ELECTRICAL SEQUENCE	Page 11
OPERATION: Water	Page 12
OPERATION: Refrigeration	Page 13
TECHNICAL CHARACTERISTICS	Page 14
MAINTENANCE AND CLEANING	Page 15
SENSOR MAINTENANCE	Page 16
BEARING MAINTENANCE	Page 17
MAINTENANCE AND CLEANING: Auger	Page 18
SERVICE DIAGNOSIS	Page 19
SERVICE DIAGNOSIS:	Page 20
CONTROL SYSTEM DIAGNOSTICS	Page 21
REMOVAL AND REPLACEMENT: Water Reservoir & Bin Controls	Page 22
REMOVAL AND REPLACEMENT: Bearing And Breaker	Page 23
REMOVAL AND REPLACEMENT: Auger	Page 24
REMOVAL AND REPLACEMENT: Water Seal	Page 25
REMOVAL AND REPLACEMENT: Evaporator	Page 26
REMOVAL AND REPLACEMENT: Evaporator	Page 27
REMOVAL AND REPLACEMENT: Gearmotor	Page 28
REFRIGERATION SYSTEM SERVICE	Page 29

This manual was printed on recycled paper.
Keep it for future reference.

Note these symbols when they appear.

 **CAUTION**  **WARNING**

They mark a section that concerns potential hazards.

NSE654

FOR THE INSTALLER

Installation Limitations:

This ice system is designed to be installed indoors, in a controlled environment:

	Min.	Max.
Air Temperature	50°F	100°F
Water Temperature	40°F	100°F
Water Pressure	20 PSI	80 PSI
Voltage	104	126

(Compared to the nameplate)

Operating the machine outside of the limitations is misuse and can void the warranty.

When installing a new system, check to be sure that you have everything you need before beginning:

Correct Ice Machine (air or water cooled)

All kits, legs, and information required for the specific job.

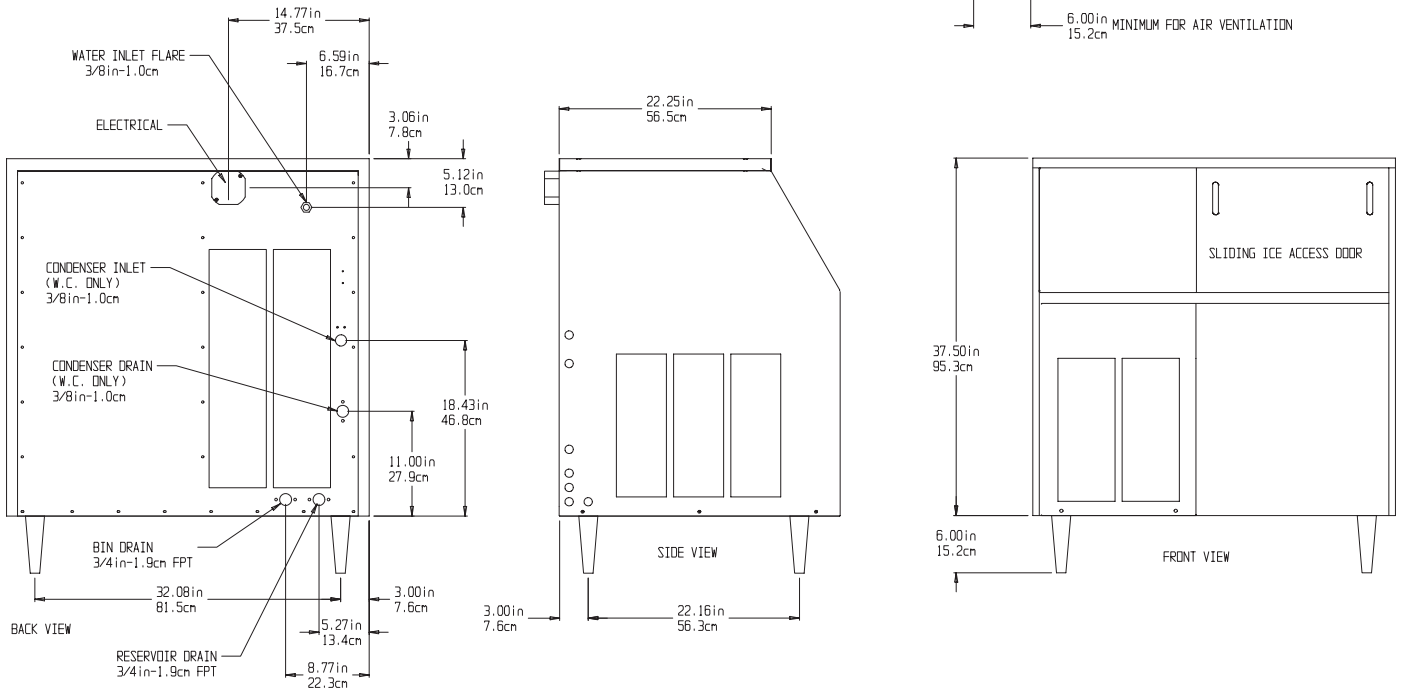

SPECIFICATIONS: ICE MAKER

Model Number	Model Series	Dimensions (w/o legs) H x W x D	Basic Electrical	Ice Type	Condenser Type	Minimum Circuit Ampacity	Maximum Fuse Size	Refrigerant Charge (R-404A)
NSE654AS-1	A or B	37.5" x 38.06" x 29.5"	115/60/1	NUGGET	Air	20	35	25 ounces
NSE654WS-1	A	same	same	NUGGET	Water	20	30	20 ounces
NSE654WS-1	B	same	same	same	same	same	same	19 ounces

Note: Minimum Circuit Ampacity is used to determine wire size and type per national electric code.

FOR THE INSTALLER: Environmental Limitations

Location

After uncrating the machine, and inspecting it for freight damage, the unit is ready for installation.

It is important that the machine be installed in a location where it has enough space for service access. The unit will require removal of the top panel for some service, so in under counter applications, the unit will either have to be pulled out, or the countertop will have to be removable.

Utility installation needs some space at the back of the cabinet, the minimum is 6 inches.

On air cooled models, the air flow must be given consideration: the unit takes in air from the front, and exhausts it through the left and back panels. These areas require at least 6 inches of air space to exhaust the hot air.

Water Limitations

An ice machine is a food manufacturing plant; it takes a raw material, water, and turns it into a food product, ice. The purity of the water is very important in obtaining pure ice and in maximizing product life. This section is not intended as a complete resource for water questions, but it does offer these general recommendations:

1. Filter the water used to produce ice. That is the water going to the "potable" water connection. Water filters vary greatly in ability and function. Install one that filters out suspended solids to a dimension of 5 microns or smaller. The finer the filter the better, but finer filters will clog sooner than course ones. It may be necessary to add a course filter ahead of the fine filter to prolong filter life.
2. Check with a water treatment specialist for a water test, and recommendations regarding filters and treatment.

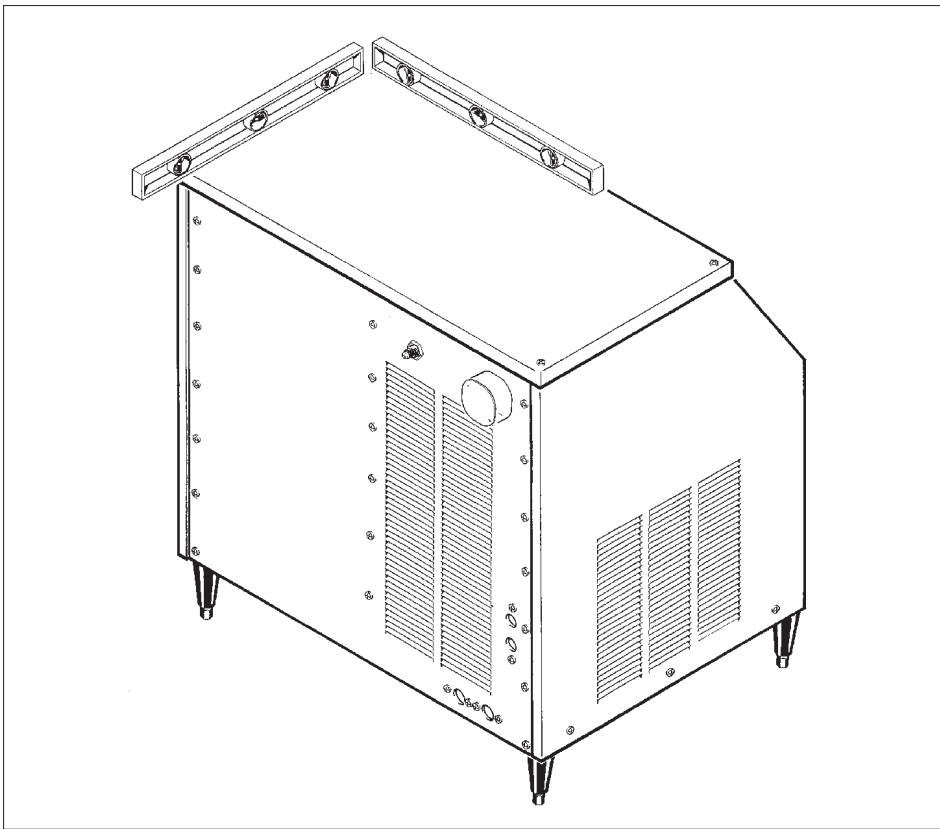

Legs

The legs (when used) may now be installed. Either use a mechanical lift to hoist the cabinet high enough to screw in the legs, or carefully lay the unit on its back (using portions of the carton to protect the back panel) and screw the legs in. Note: the legs must be threaded in all the way for maximum strength.

Scotsman Ice Systems are designed and manufactured with the highest regard for safety and performance. They meet or exceed the standards of UL, NSF, and CUL.

Scotsman assumes no liability or responsibility of any kind for products manufactured by Scotsman that have been altered in any way, including the use of any part and/or other components not specifically approved by Scotsman.

Scotsman reserves the right to make design changes and/or improvements at any time. Specifications and design are subject to change without notice.

NSE654

FOR THE PLUMBER

CONFORM TO ALL APPLICABLE CODES

Water Inlet

Air Cooled Models: Connect a cold potable water supply to the 3/8" male flare fitting at the back of the cabinet. Install a hand valve near the machine to control the water supply.

Water Treatment: In most areas, a water filter of some type will be useful. In areas where the water is highly concentrated with minerals the water should be tested by a water treatment specialist, and the recommendations of the specialist regarding filtration and/or treatment should be followed.

Water Cooled Models: Connect a separate 3/8" O.D. copper line, with a separate hand valve to control it, to the 3/8" FPT condenser inlet at the back of the cabinet. The water pressure to all lines must always be above 20 psig, and below 80 psig.

Drains

Air Cooled Models: There are two 3/4" FPT drains at the back of the cabinet. Connect a drain tube to each. These are gravity type drains, and 1/4 inch per foot fall is an acceptable pitch for the drain tubing. Install a vent at the highest point of each drain line, and the ideal drain receptacle would be a trapped and vented floor drain. **Use only 3/4" rigid tubing.**

Water Cooled Models: In addition to the above mentioned drains, a separate condenser drain must be installed. Connect it to the 1/2" condenser drain connection at the back of the cabinet.

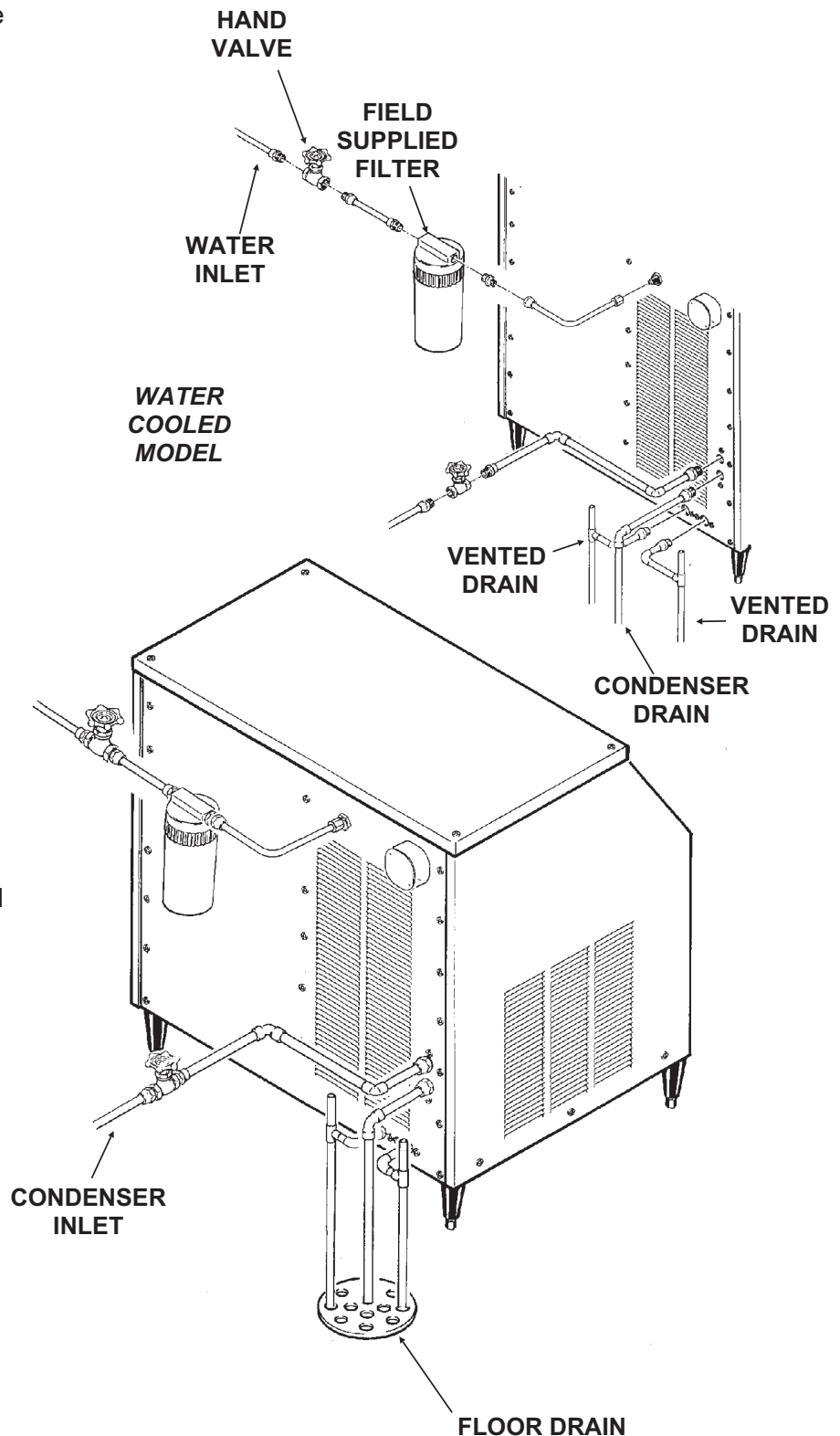

FOR THE ELECTRICIAN

CONFORM TO ALL APPLICABLE CODES

The electrical power to the unit is supplied through the junction box at the rear of the machine. Check the nameplate (located on the back panel) for the voltage requirements, and for the minimum circuit ampacity. The machine requires a solid chassis to earth ground wire.

The ice maker should be connected to its own electrical circuit so it would be individually fused. Voltage variation must remain within design limitations, even under starting conditions.

All external wiring must conform to national, state, and local electrical codes. The use of a licensed electrician is required to perform the electrical installation.

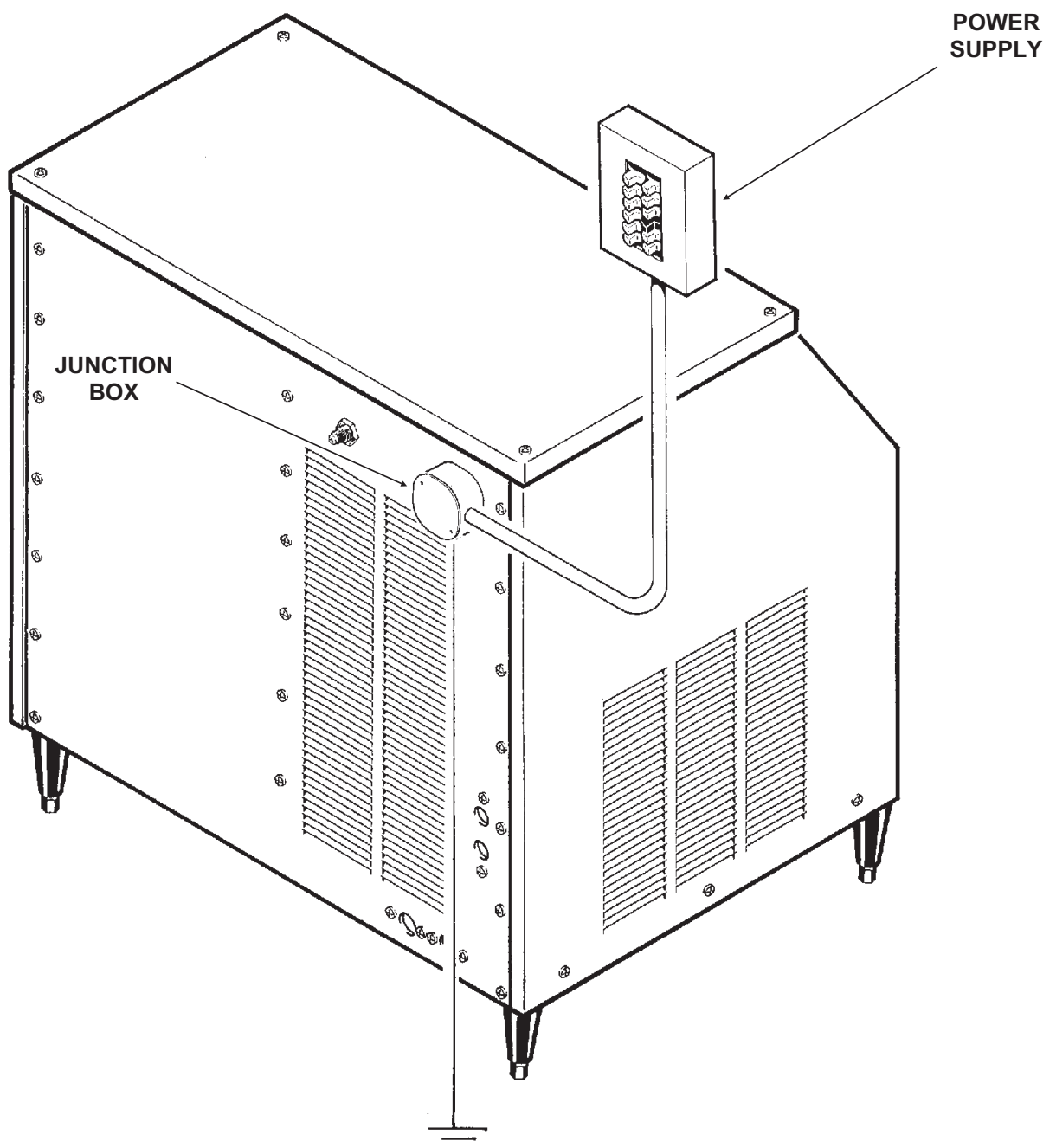

NSE654

FOR THE INSTALLER

Final Check List

1. Is the ice system installed indoors in a location where the air and water temperatures are controlled, and where they do not exceed the design limitations?
2. Is there an electrical service disconnect within sight of the installed machine? Has the voltage been checked, and compared to nameplate requirements?
3. Have all the plumbing connections been made and checked for leaks?
4. Has the machine been leveled?
5. Is there a minimum of 6" clearance at the back and left side of the machine for proper service access and air circulation? (air cooled)
LEVELED?
6. Is the water pressure a minimum of 20 psig?
7. Is the unit grounded?
8. Is there clearance over the top of the machine for service access?
9. Is there a water shut off valve installed near the machine?
10. Have all of the shipping blocks been removed?

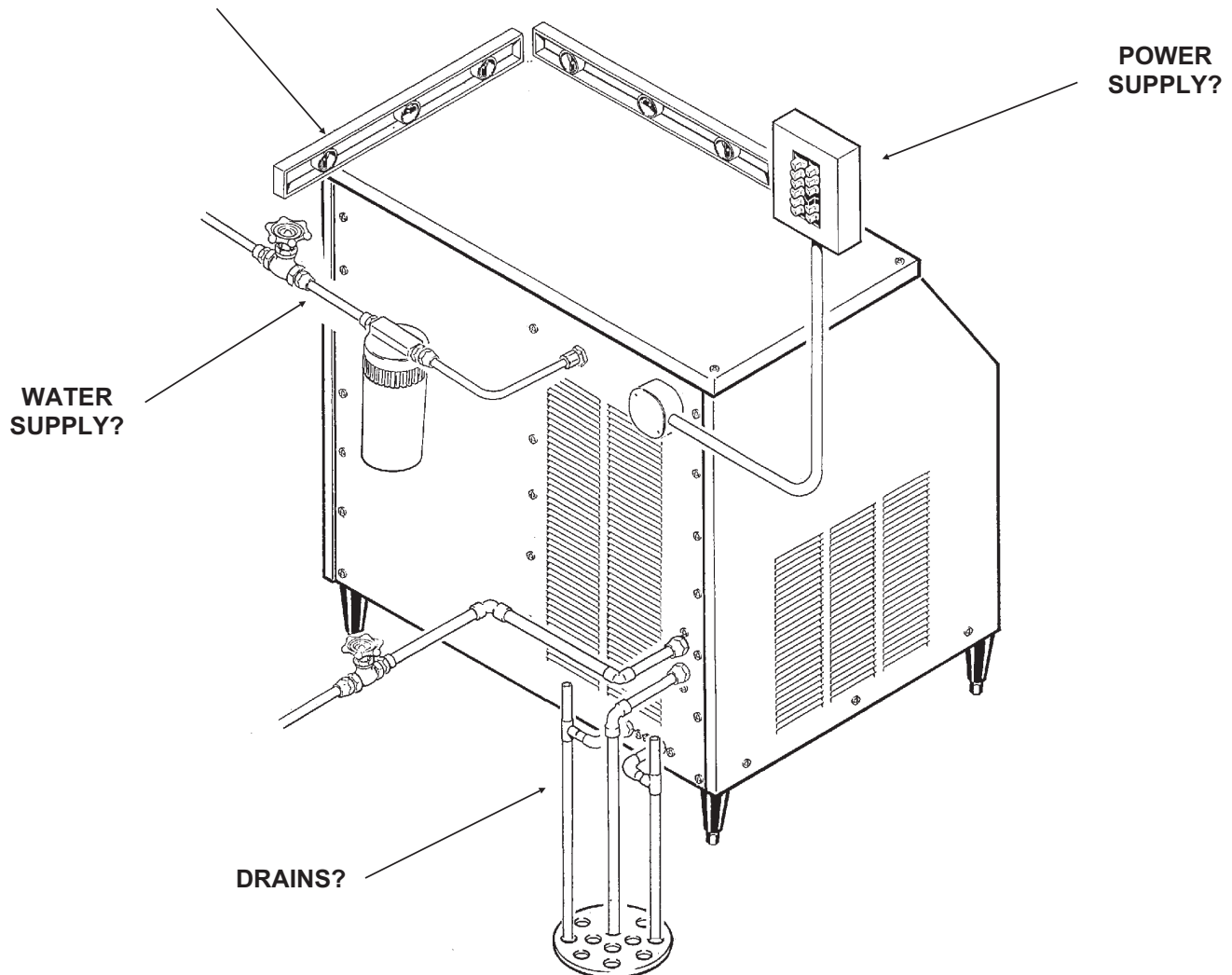

START UP

Pre-Start Inspection

1. Remove the front panels.
2. Check that the styrofoam shipping blocks have been removed.
3. Inspect the interior of the machine for loose screws or wires. Check that no refrigerant lines are rubbing each other. Check that the fan blade turns freely (air cooled).
4. Check that the unit is installed correctly according to the final check list (page 6).

Start Up

1. Go through the prestart inspection.
2. Open the hand valve, observe that water enters the water reservoir, fills the tube from the reservoir to the evaporator, and then shuts off. Check for leaks.
3. Switch the master switch on.
The electrical start up sequence is automatic.
 - A. There should be a short (15 second) delay before the gearmotor starts.
 - B. After the gearmotor starts, the compressor will start.
4. On air cooled models, the condenser will begin to discharge warm air, on water cooled models, the water regulating valve will open, and warm water will be discharged into the drain.
5. The unit should soon be making ice, if desired, the low side pressure can be checked: it should be 34 psig + or - 4 psig.
The suction line temperature at the compressor is normally very cold, nearly to the point of frost up to the compressor body, but not on it.
The air cooled discharge pressure will depend upon air and water temperatures, but should be between 220 psig and 300 psig.
The water cooled discharge pressure should be constant at about 245 psig.

The above numbers are for new, clean machines, you can expect to see some values higher, and some lower between different units.

6. THERE ARE NO ADJUSTMENTS TO MAKE, so replace the panels.

7. Clean and/or sanitize the storage bin interior, wipe off the exterior with a clean, damp cloth.

8. Give the owner/user the service manual, instruct him/her in the operation of the unit, and make sure they know who to call for service.

9. Fill out the manufacturers registration card, and mail it to the Scotsman Factory.

10. Fill out the Customer Evaluation & Warranty Registration Form, and mail it to Scotsman.

NSE654

COMPONENT DESCRIPTION

Control Box: Contains the electrical controls that operate the machine.

High Pressure Cut Out Switch: An automatic reset switch sensing the high side refrigeration pressure. It is set to shut the machine off if the discharge pressure should ever exceed 450 psig.

Compressor: The refrigerant vapor pump.

Reservoir: Float operated, it maintains the water level in the evaporator at a constant level, it also contains the water level sensor.

Water Level Sensor: Senses if there is water in the reservoir to make ice out of. Will shut the machine off if there is none.

Ice Discharge Chute: Directs the ice produced by the evaporator into the storage bin.

Ice Level Sensor: An electronic "eye", it senses the presence of ice in the bottom of the ice discharge chute. Operates to turn the ice machine on and off automatically as the level of ice in the bin changes.

Gear Motor: An oil filled, speed reduction gearbox, driving the auger.

Condenser: Air or water cooled, where the heat removed in ice making is discharged.

Expansion valve: The refrigerant metering device.

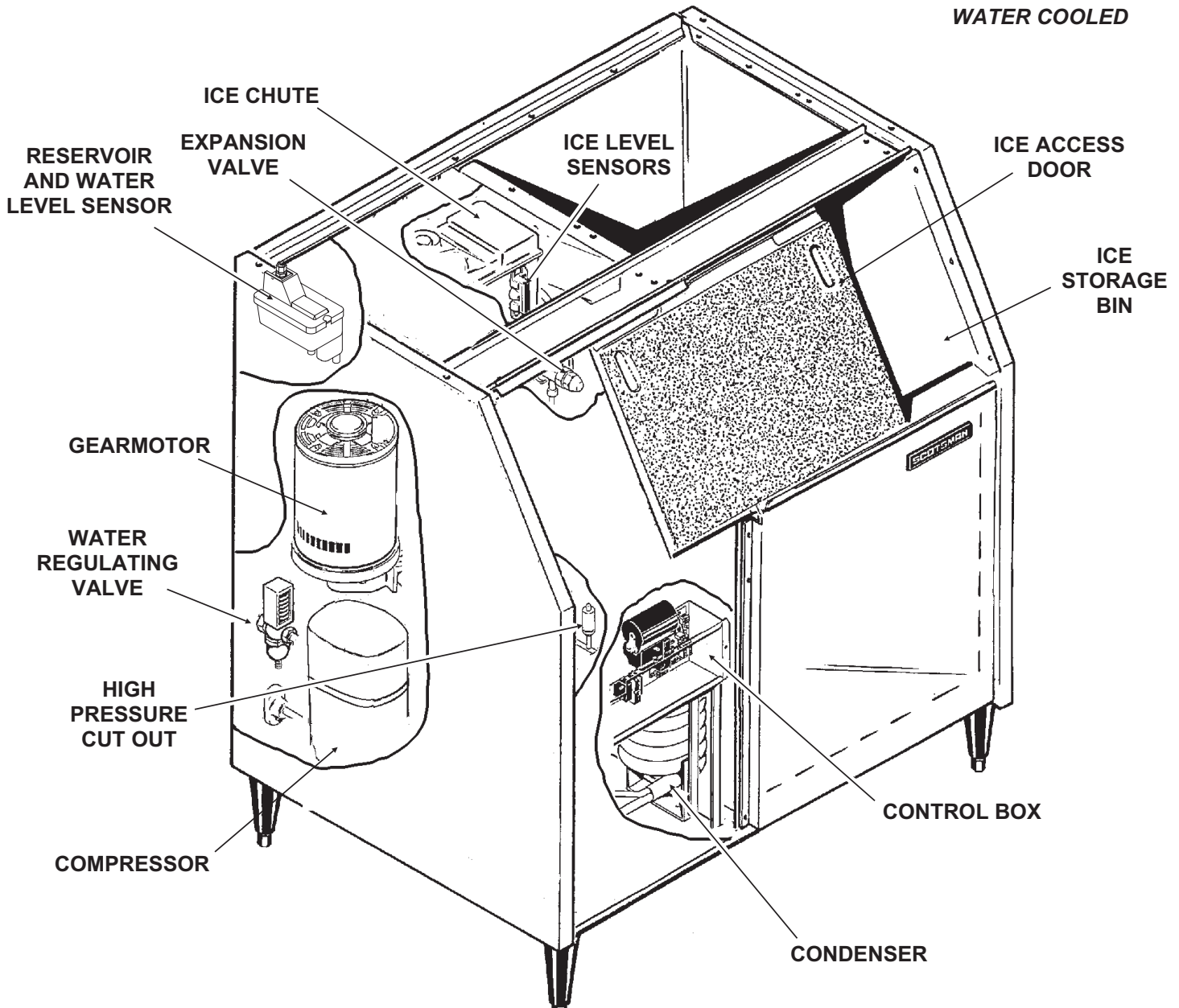

COMPONENT DESCRIPTION

Evaporator: A refrigerated vertical tube filled with water and containing a water seal and auger.

Auger: A solid stainless steel double spiral auger, it pushes the ice crystals up to the top of the evaporator.

Water Seal: A two part "face" seal, the top half rotating with the auger, the bottom half stationary, the sealing action being where the two seal "faces" meet.

Ice Sweep: A plastic cap with "fingers". It revolves with the auger to "sweep" the ice into the ice chute.

Breaker: Where the ice is compressed and much of the extra water is squeezed out of it before it is discharged into the bin.

Motor: A split phase motor that drives the gear reducer.

Thrust Bearing: As the ice is pushed up the evaporator, the auger is thrust down, and pressure from the auger thrust is taken up by this bearing.

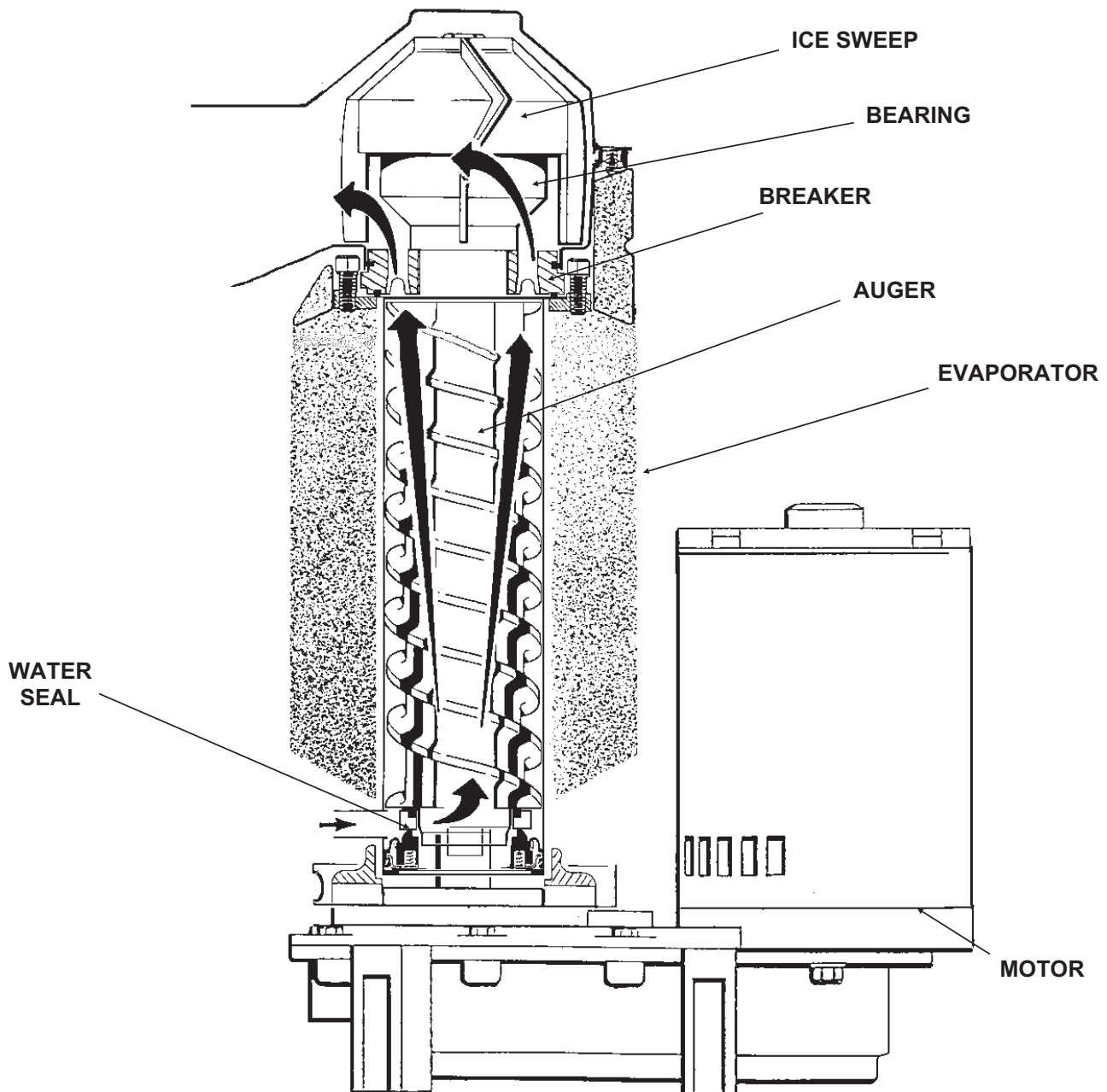

NSE654

COMPONENT DESCRIPTION: Control Box

Contactors: A definite purpose contactor connecting the compressor and the remote condenser fan motor to the power supply.

Circuit Board: Controlling the ice machine through sensors and relays. The sensors are for ice level and water level. The relays are for the gear motor (with a built in time delay to clear the evaporator of ice when the unit turns off) and for the compressor.

Low Pressure Cut Out Switch: An automatic reset control that shuts off the ice machine when the low side pressure drops below a preset point, 0-4 psig.

Potential Relay: The compressor start relay.

On/Off Switch: Manual control for the machine.

Control Board

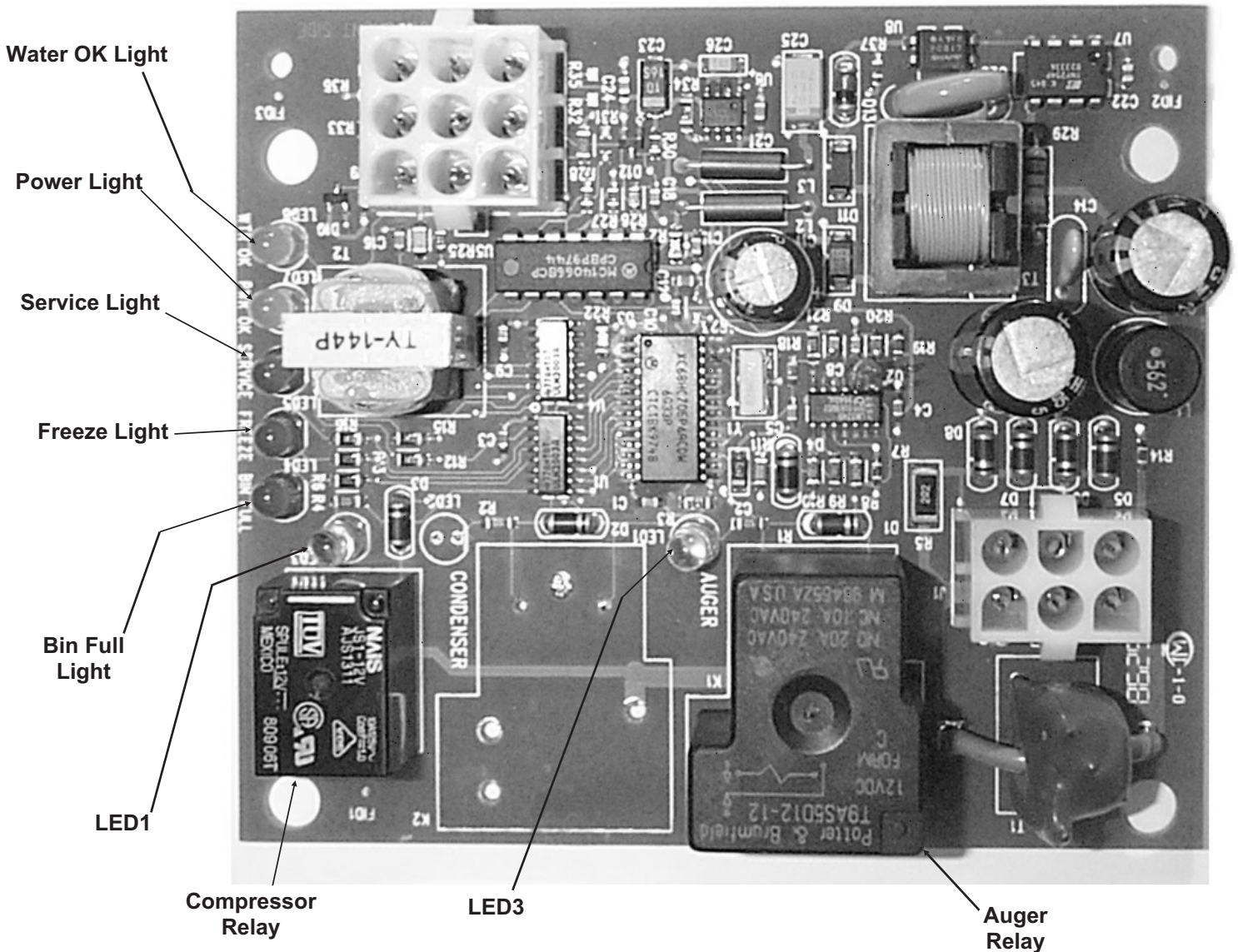

ELECTRICAL SEQUENCE

There are 7 indicator lights on the control board:

- **WTR-OK.** Water OK. Normal = Glowing. Glows when there is water in the reservoir.
- **PWR-OK.** Power OK. Normal = Glowing. Glows when the control board has power **and** is functional.
- **Service.** Normally Off.
- **Freeze.** Normally Glowing when making ice.
- **Bin Full.** Normally Off when making ice.
- **LED1.** Normally Glowing when making ice.
- **LED3.** Normally Glowing when making ice.

If the machine is switched off at the mode switch, but is otherwise ready to go, switching the mode switch to ON does the following:

- The PWR-OK light glows.
- If there is water in the reservoir the WTR-OK light glows.
- After 10 seconds the Freeze, LED1 and LED3 lights glow and the machine starts up.

Start Up:

- The compressor relay and auger motor relay become energized, connecting power to the windings of the auger motor and contactor coil.
- The contactor is energized, connecting power to the compressor, and the compressor starts.
- During normal operation ice passes between the ice level sensors but only interrupts their infrared beam momentarily. The bin full light remains off and the machine stays on until ice builds up in the bin and blocks the path between the sensors for 6 seconds or longer. When that occurs the bin full light glows and the machine shuts down.

Ice Vending

When the glass filler lever is pushed in the vend switch closes connecting power to the ice chute door solenoid and agitator drive motor.

Optional Portion Control: The portion control module will power the agitator drive motor for a set length of time. The amount of time is controlled by the setting of the portion control knob.

Holding the glass filler lever in will not cause additional dispensing, unless the portion control is set for continuous dispensing. Releasing and re-pushing the glass filler lever will repeat the dispense cycle.

Shut Down:

- The compressor relay opens, LED1 goes out.
- The compressor contactor opens
- The compressor stops
- The auger motor stays on for 1 more minute, clearing out ice in the evaporator, and then
- The auger motor relay opens, LED3 goes out and the auger motor stops.

The compressor will not restart until 2 minutes or more have passed after the last shut down.

If the path between the ice level sensors remains clear for more than 10 seconds the ice machine will restart.

Another purpose of the control board is to turn the machine off when necessary:

- When the water level in the reservoir falls below the water level sensor's tip, the WTR-OK light goes out and the machine shuts down. When water refills the reservoir the WTR-OK light glows and the machine starts up again.
- If the auger drive motor current becomes excessive the compressor and auger drive motor will be switched Off and the Service light will blink. The control board will restart the auger drive motor in 4 minutes. If during the first 60 seconds after restart the auger motor current stays within limits, the compressor is restarted and the machine returns to normal operation. If the current is excessive within 60 seconds after the restart, the process will be repeated once more. If after that try the current is still excessive the machine shuts down and must be manually reset. The service light will then be glowing continuously.

To Reset: Disconnect and reconnect electrical power

Separate from the circuit board:

- If the high pressure cut out switch opens the machine will stop immediately. It will automatically reset when the pressure falls below its cut in point.
- If the low pressure cut out switch opens the machine will stop immediately. It will automatically reset when the pressure rises above its cut in point.
- The mode switch is the manual control for the complete machine, but it is not a service disconnect.

NSE654

OPERATION: Water

Water enters the machine through the 3/8" male flare at the rear of the cabinet, flows to the water reservoir which it enters through the float valve. The water then goes out the bottom of the reservoir tank to the bottom of the evaporator.

Reservoir overflow or evaporator condensation is routed to the drain. Water cooled models have a separate water circuit for the cooling water: it enters the fitting at the rear, goes to the water regulating valve, then to the water cooled condenser and down the drain.

The storage bin has a separate drain tube and drain fitting.

Water Level: The correct water level should be checked when the machine is making ice. Check the water level in the reservoir and compare it to the horizontal line molded into the side of the reservoir. The correct water level is between $\frac{1}{8}$ " above and $\frac{1}{4}$ " below the line. If needed, bend the float arm up or down to adjust the water level.

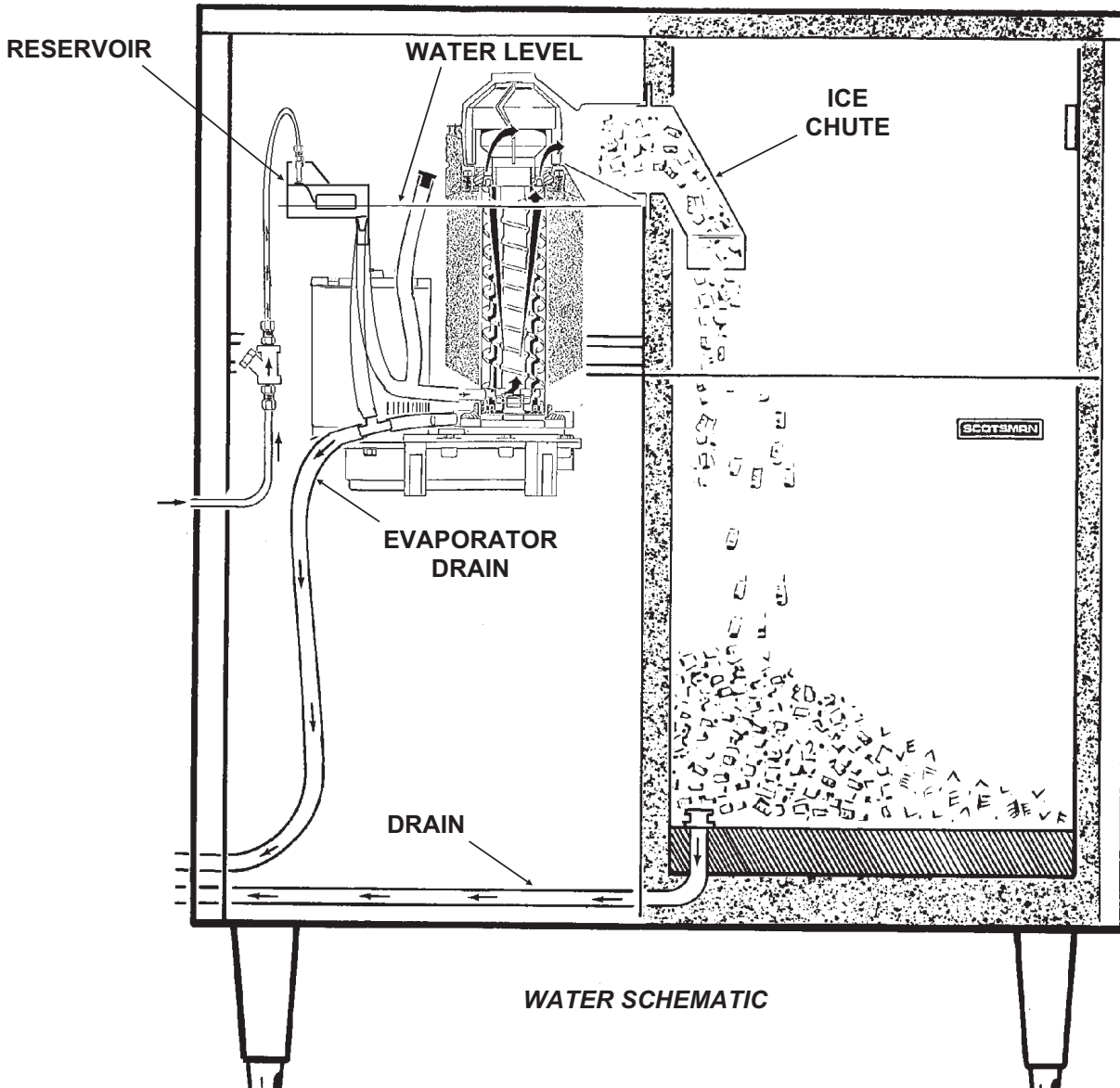

WATER SCHEMATIC

OPERATION: Refrigeration

Beginning at the compressor, the refrigerant is compressed into a high temperature gas. The discharge line directs this gas to the condenser. At the condenser (air or water cooled) the gas is cooled by either air or water and it then condenses into a liquid. This high pressure liquid then goes through the liquid line to the expansion valve. The thermostatic expansion valve meters liquid refrigerant into the evaporator, the volume of liquid refrigerant depending upon the temperature of the

evaporator; warmer evaporators get more refrigerant and colder evaporators get less. At the evaporator, the refrigerant enters an area of relatively low pressure, where it can easily "boil off" or evaporate. As it evaporates, it absorbs heat from the evaporator and whatever is in contact with it (such as the water inside it). After the evaporator, the refrigerant, now a low pressure vapor, goes through the suction line back to compressor, where the cycle is repeated.

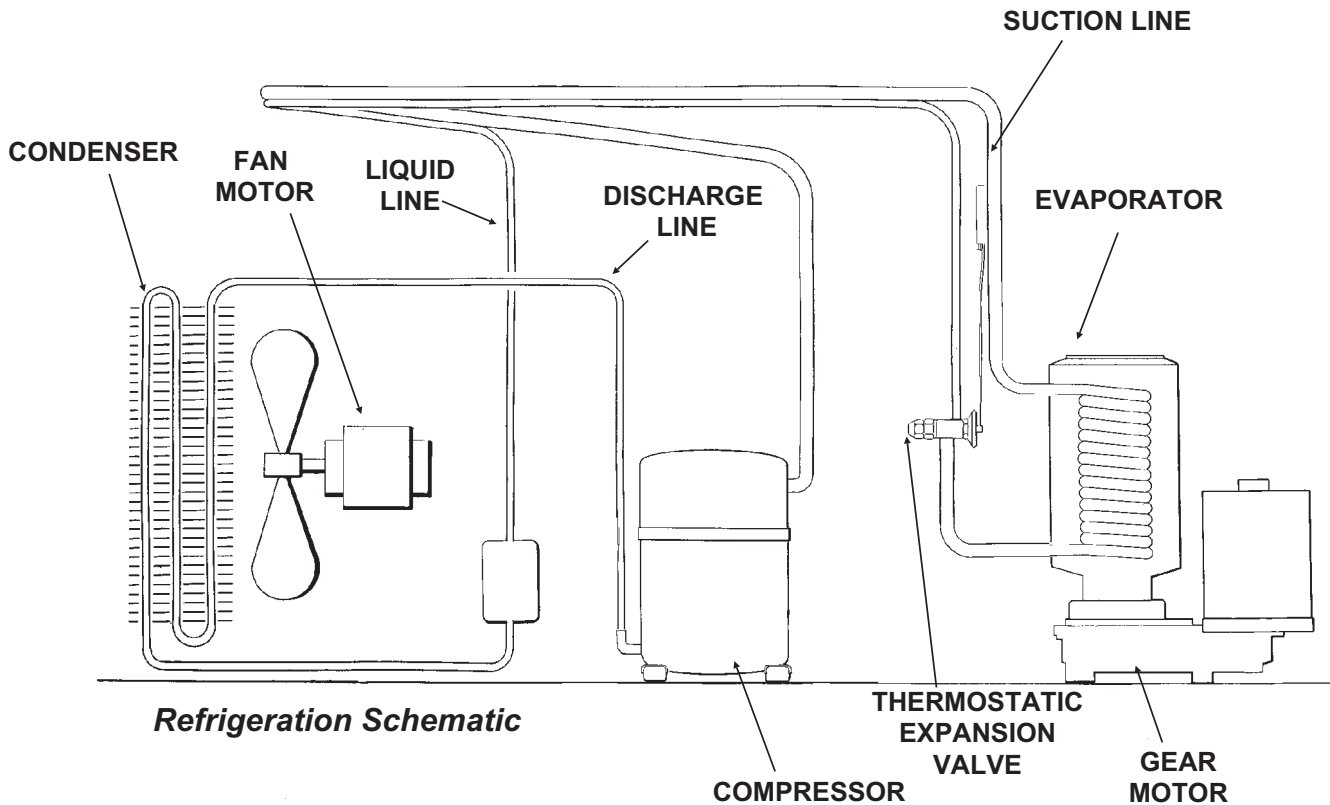

NSE654

TECHNICAL CHARACTERISTICS

Typical Low Side Pressure

- 32 - 34 PSIG, less in cooler ambients, greater in hot ambients

Typical Discharge Pressure

- 200 - 250 PSIG air cooled
- 245 PSIG water cooled

Typical Gearmotor Amp Draw

- 3.1 -3.6

Typical Compressor Amp Draw

- 8.5 to 9.1

Typical Superheat

- 7 to 9 degrees

Water Level Sensor

- Conductivity probe in the reservoir

Bin Control

- Electric Eye in the ice chute

Evaporator Material

- Stainless Steel

Auger Material

- Stainless Steel

Breaker Material

- Stainless Steel

MAINTENANCE AND CLEANING

A Scotsman Ice System represents a sizable investment of time and money in any company's business. In order to receive the best return for that investment, it **MUST** receive periodic maintenance.

It is the **USER'S RESPONSIBILITY** to see that the unit is properly maintained. It is always preferable, and less costly in the long run, to avoid possible down time by keeping it clean; adjusting it as needed; and by replacing worn parts before they can cause failure. The following is a list of recommended maintenance that will help keep the machine running with a minimum of problems.

Maintenance and Cleaning should be scheduled at a **minimum of twice per year.**

Electrical power will be ON when doing in place cleaning.

ICEMAKING SYSTEM: In place cleaning

1. Check and clean any water treatment devices, if any are installed.
2. Pull out and remove the front panel.
3. Move the ON-OFF switch to OFF.
4. Remove all the ice from the storage bin.
5. Remove the cover to the water reservoir and block the float up.
6. Drain the water reservoir and freezer assembly using the drain tube attached to the freezer water inlet. Return the drain tube to its normal upright position and replace the end cap.
7. Prepare the cleaning solution: Mix eight ounces of Scotsman Ice Machine Cleaner with three quarts of hot water. The water should be between 90-115 degrees F.

	<p>⚠ WARNING</p> <p>Scotsman Ice Machine Cleaner contains acids. These compounds may cause burns.</p> <p>If swallowed, DO NOT induce vomiting. Give large amounts of water or milk. Call Physician immediately. In case of external contact, flush with water.</p> <p>KEEP OUT OF THE REACH OF CHILDREN.</p>
---	--

8. Slowly pour the cleaning solution into the water reservoir until it is full. Wait 15 minutes, then switch the master switch to ON.
9. As the ice maker begins to use water from the reservoir, continue to add more cleaning solution to maintain a full reservoir.

10. After all of the cleaning solution has been added to the reservoir, and the reservoir is nearly empty, switch the master switch to OFF.
11. After draining the reservoir, as in step 6, wash and rinse the water reservoir.

To Sanitize:

- Mix a solution of approved sanitizer, or use 1 ounce of household bleach and 2 gallons of warm (95°F. to 115°F.) water. Repeat steps 6-11, except substitute the sanitizer for the cleaner solution.
12. Remove the block from the float in the water reservoir.
 13. Switch the master switch to ON
 14. Continue ice making for at least 15 minutes, to flush out any cleaning solution.

DO NOT USE any ice produced from the cleaning solution.

Be sure no ice remains in the bin.

15. Remove all ice from the storage bin.
16. Add warm water to the ice storage bin and thoroughly wash and rinse all surfaces within the bin.
17. Sanitize the bin interior with an approved sanitizer using the directions for that sanitizer.
18. Replace the front panel.

NSE654

SENSOR MAINTENANCE

1. The bin control uses devices that sense light, therefore they must be kept clean enough so that they can “see”. At least twice a year, remove the bin control sensors from the base of the ice chute, and wipe the inside clean, as illustrated.

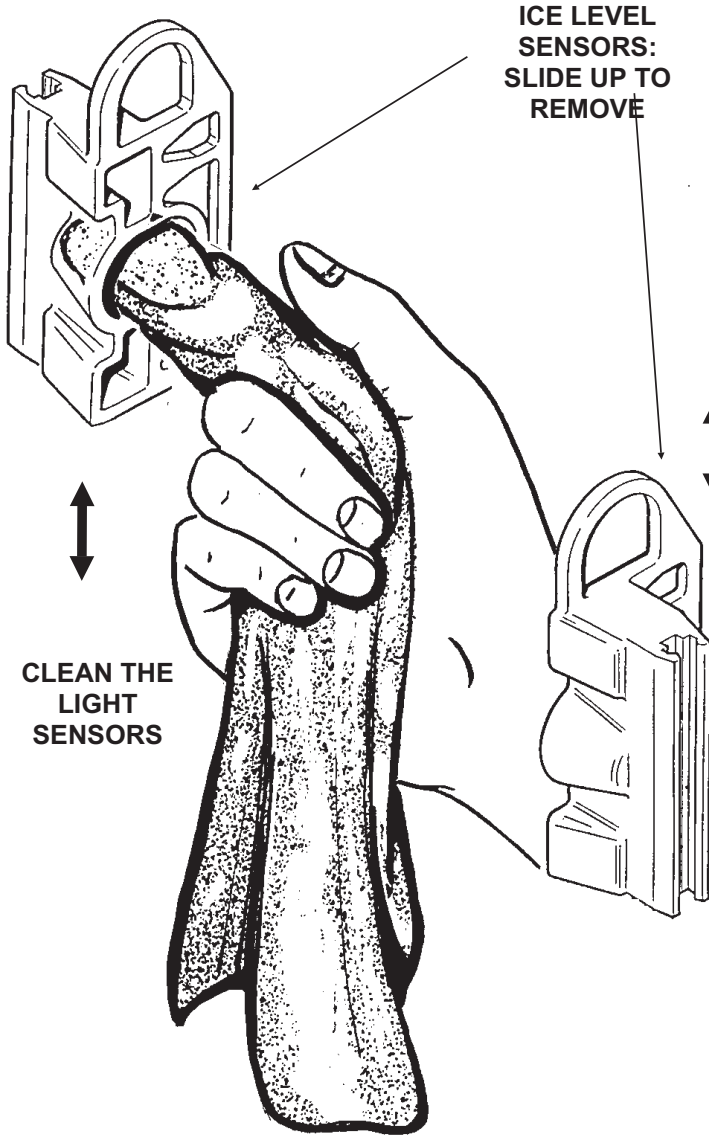

2. The ice machine senses water level by a probe located in the water reservoir. At least twice a year, the probe should be removed from the reservoir, and the tip wiped clean of mineral build-up.

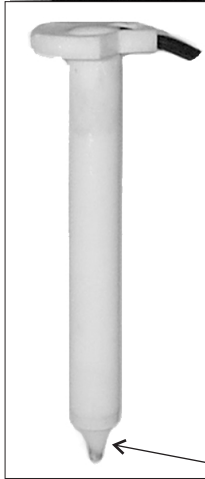
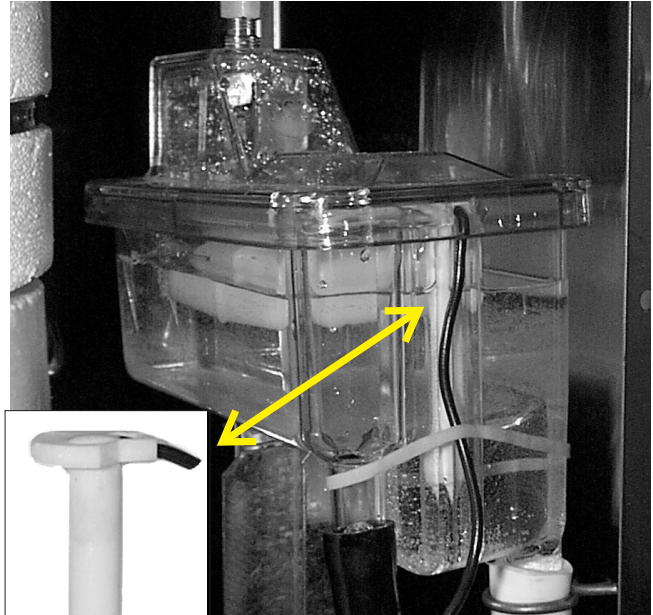

Clean the Probe's Tip with ice machine cleaner and a clean, soft cloth.

BEARING MAINTENANCE

The bearing in the breaker should also be checked at least **two times per year**.

A. Check the bearing by:

- removing the ice chute cover

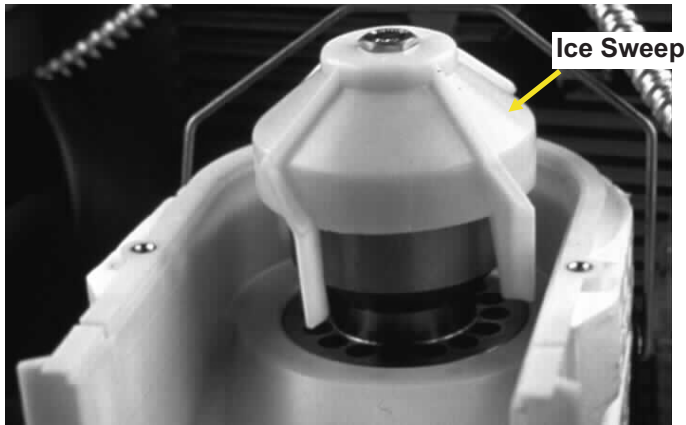

- unscrewing the ice sweep
- removing the water shed

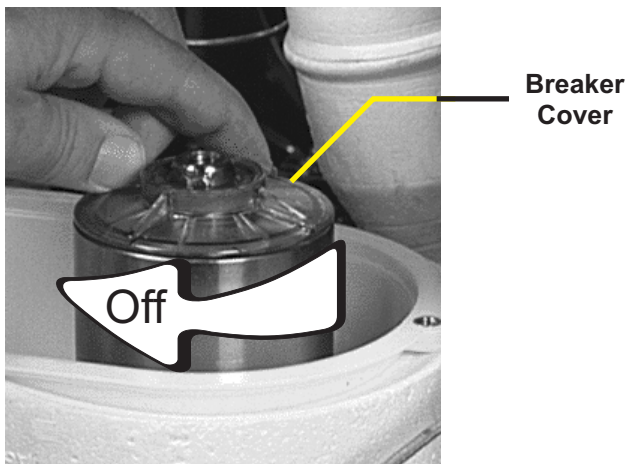

- unscrewing the breaker cover.

- unscrewing the auger stud

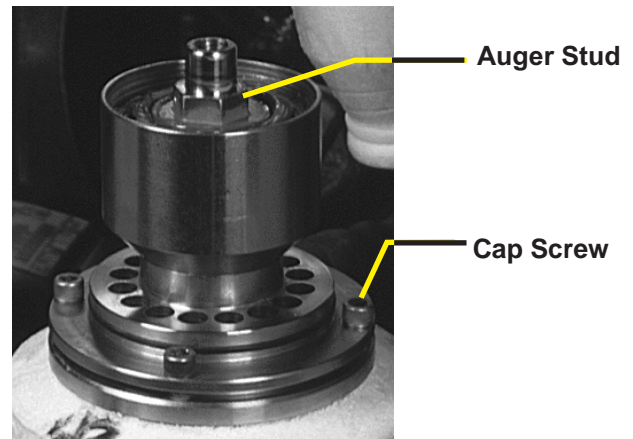

Inspect the bearing. There should be plenty of grease in sight. If grease is needed the bearing and breaker should be removed to check the action of the bearing. It should rotate smoothly.

To remove the breaker remove the lower ice chute then take out all four allen head cap screws and pull the breaker off the auger and evaporator.

If the bearing only needs grease, inject grease into the bearing using Scotsman grease needle pn 02-3559-01 and Scotsman bearing grease cartridge, pn A36808-001. Be sure to inject grease evenly and thoroughly.

See Removal and Replacement section to replace bearing or seals.

Reverse to reassemble.

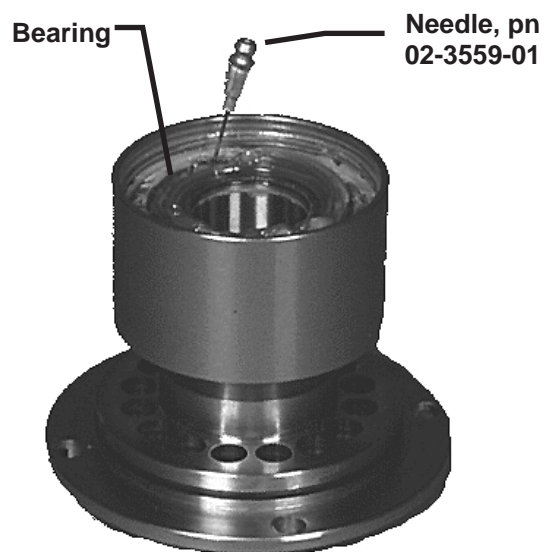

NSE654

MAINTENANCE AND CLEANING: Auger

	⚠ WARNING
	Moving Parts Hazard. Moving fan blade can cause personal injury. Disconnect electrical power before beginning.

5. Clean the air cooled condenser:

Use a vacuum cleaner or coil cleaner if needed.
Do NOT use a wire brush.

Disconnect electrical power, and remove the filter.
The filter may be cleaned or replaced.

Clean the condenser: the condenser may appear to be clean on the surface, but it can still be clogged internally. Check with a flash light from the front to see if light can be seen through the condenser fins.

In some areas, the water supply to the ice maker will contain a high concentration of minerals, and that will result in an evaporator and auger becoming coated with these minerals, requiring a more frequent removal than twice per year. If in doubt about the condition of the evaporator and auger, the auger can be removed so the parts can be inspected.

Note: Water filters can filter out suspended solids, but not dissolved solids. "Soft" water may not be the complete answer. Check with a water treatment specialist regarding water treatment.

For more information on removal of these parts, see REMOVAL AND REPLACEMENT.

	⚠ WARNING
	Moving Parts Hazard. Rotating Auger can cause personal injury. Disconnect electrical power before beginning.

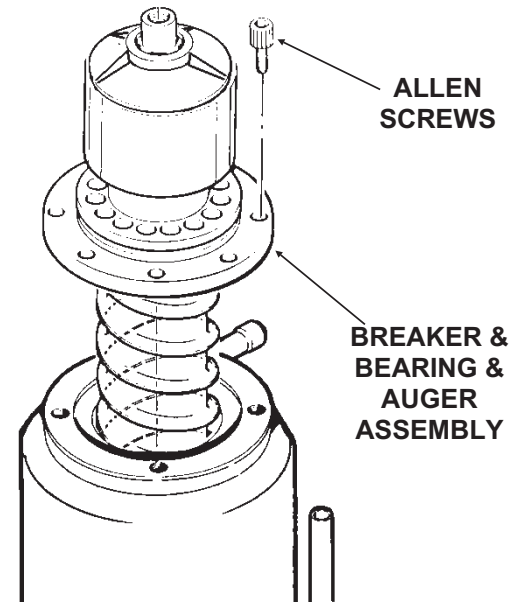

1. To remove the auger, remove the front and top panels.
2. Use drain hose to drain the evaporator.
3. Remove bail clamp holding ice chute cover to ice chute, and remove cover.
4. Unscrew and remove ice sweep.
5. Remove ice chute from evaporator.
6. Remove 4 allen screws holding breaker to evaporator.
7. Pull up to remove auger.

After the auger has been removed, allow the auger to dry: if the auger is not bright and shiny, it must be cleaned.

Clean the auger and evaporator as required. **DO NOT HONE THE EVAPORATOR.**

8. Replace the water seal.
9. Reverse to reassemble.

SERVICE DIAGNOSIS

Symptom	Possible Cause	Probable Correction	
No ice is made, nothing operates	Unit off due to no power	Restore Power	
	Unit off due to master switch in OFF position.	Switch master switch to ON.	
	Unit off due to low water level.	Check water supply, filter, strainer, float valve. Correct water supply.	
	Unit off due to ice level sensors (photo-electric eyes) blocked.	Check/clean ice level sensors.	
	Unit off due to scale on water level sensor.	Clean water level sensor.	
	Unit off due to high pressure control open.	Check for water interruption (water cooled) or fan motor failure (air cooled).	
	Auger motor hums but does not turn.	Auger can't turn. Circuit board has not yet shut unit down.	
	Unit is shut down	Circuit board has shut ice machine down due to high auger motor amp draw. Check for cause of high amp draw, including bearings, gearmotor condition and scale on auger and in evaporator.	
	Low pressure control open		Auger not turning due to: motor failure; auger relay failure on circuit board; or gears stripped. Check drive train.
			TXV restricted or not metering. Check bulb temperature.
			Lack of refrigerant. Check for leak. Check for a restricted system
	No power to circuit board.		Low pressure control open. See above
			High pressure control open. Fan motor failure (a/c) or water shut off (w/c)
			Check harness
Circuit Board gear motor relay will not close		Check, replace board	
Water level or ice level sensor failed.		Check, replace sensor	
No ice, auger motor is turning	Compressor contactor coil is open	Check/replace contactor	
	Compressor will not start	Check start capacitor.	
		Check start relay	
		Check compressor windings	
Circuit board compressor relay will not close.		Check, replace board	
Unit makes ice, but very slowly.	High discharge pressure because of a dirty condenser	Clean the air filter and condenser.	
	Low capacity because the auger and evaporator are coated with mineral scale	Clean the water system	
	Low suction pressure due to low refrigerant charge	Locate leak. Recover refrigerant, repair leak, replace dryer, evacuate and weigh in the nameplate charge	

NSE654

SERVICE DIAGNOSIS:

Symptom	Possible Cause	Probable Correction
Water Leak	Drain plugged up	Clean out drain
	Tubing cracked	Replace tubing
	Condensation on drain tubing	Insulate tubing
	Hose off	Reattach hose
	Reservoir cover off	Return cover to reservoir
	Reservoir cracked	Replace reservoir
	Evaporator water seal leaks	Check base of evaporator & drip pan. If the seal leaks, shut off the water, remove the auger, replace the water seal. Check gear motor for water infiltration.
Excessive water use	Water cooled model, water regulating valve not adjusted properly.	Adjust to 245 PSIG discharge pressure
	Reservoir float valve leaks thru	Replace float valve or seat
	Water cooled model, overcharged with refrigerant	Recover and weigh refrigerant. Weigh in correct charge.
	Water cooled model, condenser coated with minerals	Acid clean water cooled condenser.
Excessive ice meltage	Bin drain clogged	Clean out bin drain.
	Improper installation of drains, they are connected.	Drains must be separate.
	Poor fit between bin door and door frame	Adjust or replace
Machine makes too much noise	Evaporator coated internally with minerals	Clean with Scotsman Ice Machine Cleaner
	Motor bearings dry	Oil or replace motor

CONTROL SYSTEM DIAGNOSTICS

The control system consists of:

- Control Board
- Water Sensor
- Ice Sensors
- High Pressure Cut Out
- Low Pressure Cut Out

If the unit is OFF, check the **control board**:

1. Is the Power OK light on? If not check power to the unit. If it has power, and the Power OK light is NOT on, check the high pressure and low pressure cut outs. If they are both closed, replace the board. If the Power OK light is ON, go to the next step.

2. Is the Water OK light on? If it is, go to the next step. If not, check the water level in the reservoir. If there is water in the reservoir, check that the water sensor is plugged in. To check the **water sensor**:

- A. Unplug water sensor.
- B. Pull water sensor from reservoir.
- C. Place one ohmmeter lead on the sensor's plug and the other on the sensor's tip. The meter should show nearly zero resistance. If it reads infinite resistance, check the tip for corrosion. If it is clean and still reads open, replace the sensor.

OR connect a copper wire to the wire where the water sensor plugs into and place the other end in the water. The water OK light should go ON. If it does not, replace the control board.

3. **Ice sensor check.** Is the Bin Full light Off? If it is OFF and the Service light is Off, and the unit is not running, replace the control board.

If it is OFF and the auger motor is running but the compressor is not, check the compressor contactor coil.

If it is on, the ice sensors may be blocked. Remove them and check for mineral scale. Scotsman's test box can also be used to determine if the ice sensors or board are defective.

Using the tester:

A. Disconnect the ice sensors at the connection by the ice chute. Connect the LED and PHOTO TRANS wires to the control board's wires.

B. With the On - Off (mode) switch in either position, move the Bin Full switch on the tester to Bin Full - the tester's light will blink and after a few seconds the bin full light on the control board will come on. If not, replace the board.

Move the Bin switch on the tester to Bin Empty. The light on the tester will go out, and after a few

seconds the Bin Full light on the board will go out. If master switch is ON, the unit should start.

4. **High pressure** cut out check.

Disconnect electrical power.

Pull the wires off the high pressure cut out.

Use an ohmmeter to determine if the switch is OPEN, If it is, check the discharge pressure. If the discharge pressure is less than 300 PSIG, replace the high pressure cut out.

If the high pressure cut out is open and the system has high discharge pressure, check for the cause.

5. **Low pressure** cut out check.

Disconnect electrical power.

Pull the wires off the low pressure cut out.

Use an ohmmeter to determine if the switch is OPEN, If it is, check the suction pressure. If the suction pressure is greater than 20 PSIG, replace the low pressure cut out.

If the low pressure cut out is open and the system has low suction pressure, check for the cause.

NSE654

REMOVAL AND REPLACEMENT: Water Reservoir & Bin Controls

WATER RESERVOIR

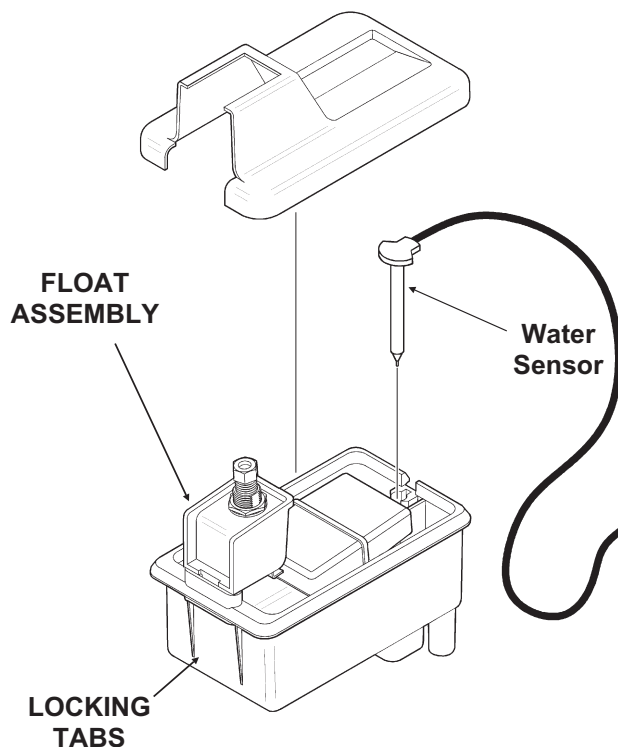

1. Shut off the water supply to the icemaker.
2. Remove front panel and reservoir cover.
3. Disconnect water inlet line from float valve.
4. To remove float only, push in the locking tab under the float valve, and pull float up and out of the reservoir.

Note: an internal plunger is available separately.

5. To remove reservoir, remove drain hose from reservoir.
6. Remove water level sensor from reservoir.
7. Remove evaporator inlet hose from reservoir.
8. Remove mounting screws from reservoir bracket, and remove reservoir from icemaker.
9. Reverse to reassemble.

BIN CONTROLS (Ice Level Sensors)

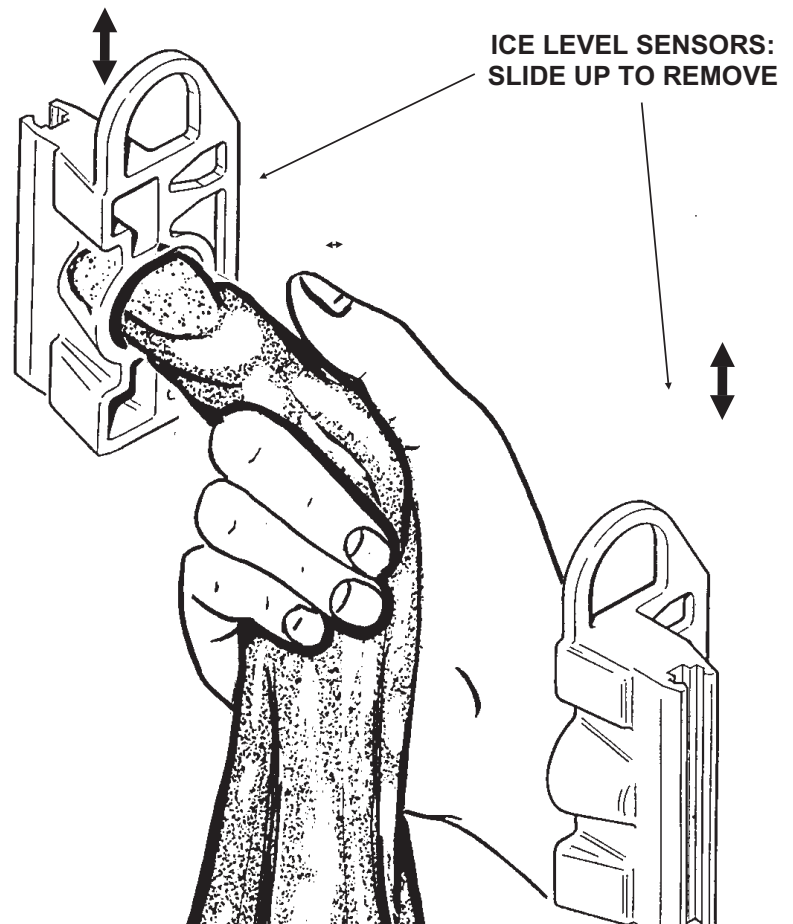

1. Disconnect electrical power.
2. Remove front panel.
3. Remove control box cover.
4. Locate ice chute, at the base of the chute, in front of and behind it are two plastic bin control mounts.
5. Pull each bin control (ice level sensor) out of the rubber mounting grommets, and in the control box, disconnect the electrical leads connecting the bin control to the circuit board.
6. Reverse to reassemble, be certain that the bin controls are aligned so that the ice level sensors are visible (centered) through the grommets in the ice chute.

REMOVAL AND REPLACEMENT: Bearing And Breaker

	<p>⚠ WARNING</p> <p>Hazardous Moving Parts. Moving auger can cause personal injury. Disconnect electrical power before beginning.</p>
---	---

Note: Removal of the auger, water seal, evaporator and gearmotor must begin at the top of the assembly.

To Remove the Breaker Bearing Assembly:

1. Remove top and front panels; disconnect electrical power.
2. Move bail clamp off ice chute cover and remove ice chute cover.
3. Unscrew and remove ice sweep.
4. Remove insulation halves from outside of ice chute, lift up and remove ice chute.
5. The breaker may be removed from the auger and evaporator without disturbing the auger.
 - a. Unscrew breaker cover from breaker (left hand threads)
 - b. Unscrew auger stud from top of auger.
 - c. Unscrew 4 allen head cap screws holding breaker to evaporator.

Step 5-a

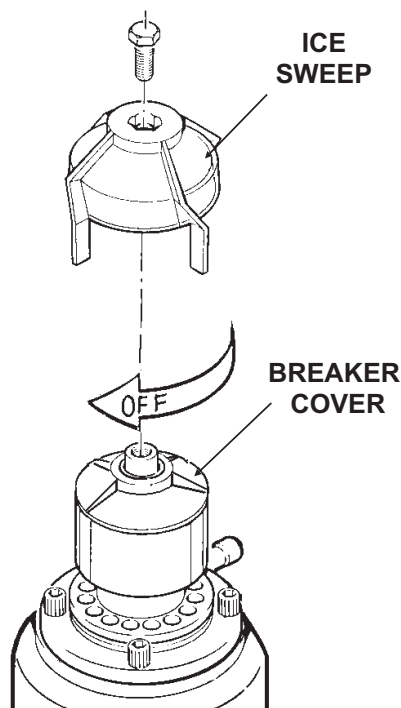

Step 5-b

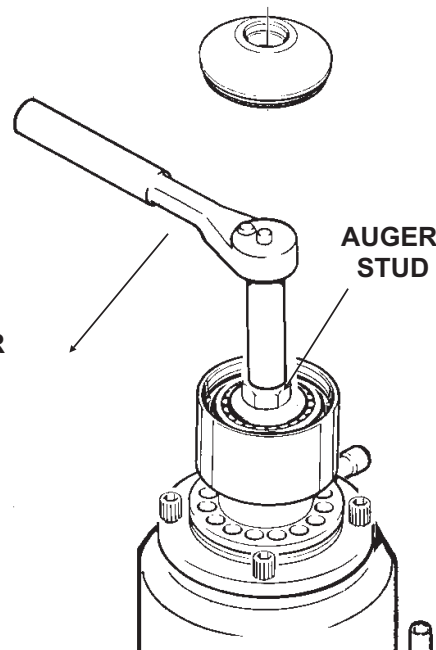

Step 5-c and Step 6

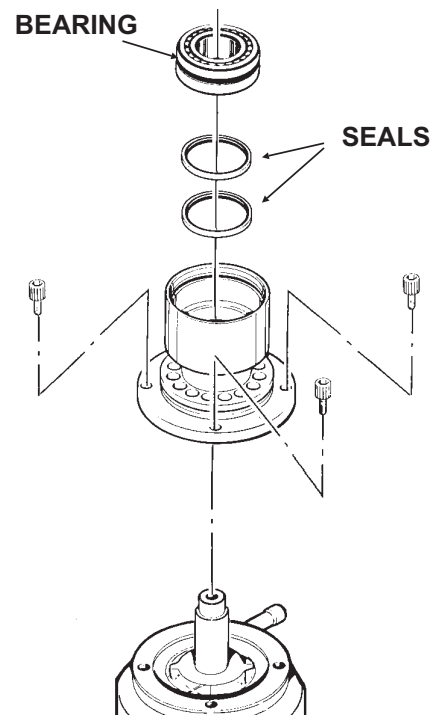

d. Lift up, and remove breaker/bearing assembly from auger & evaporator.

6. Service the bearing. Check for rust, rough spots and damage.

a. The bearing is pressed into the breaker, to remove the bearing and replace it an arbor press is needed.

b. Replace lower seals before installing new bearing in breaker.

Note: seals must be pressed in with a tool pushing against the outer edge only, they will not install by hand.

Replace parts as required. Re-grease bearing with Scotsman part no. A36808-001 bearing grease.

Replace top seal, and check the o-rings, replace if cut or torn.

7. Reverse to reassemble: specific tools and materials are required to install properly.

a. Add food grade grease such as Scotsman part number 19-0569-01 to the seal area before installing on the auger.

b. Check the seal to shaft areas for cuts, or rough spots: none are permitted.

NSE654

REMOVAL AND REPLACEMENT: Auger

	⚠ WARNING
	Moving Parts Hazard. Moving Auger can cause personal injury. Disconnect electrical power before beginning.

To Remove the Auger:

Turn off the water to the machine, and unclip the evaporator drain hose, pull it down and drain the evaporator into the bin or a container.

1. The top panel must be removed.
2. Remove ice chute cover.
3. Unscrew ice sweep.
4. Remove ice chute body.
5. The auger and breaker/bearing may now be removed as an assembly.
 - a. Unscrew 4 allen head cap screws holding breaker to evaporator.
 - b. Lift up on breaker and remove auger from evaporator.

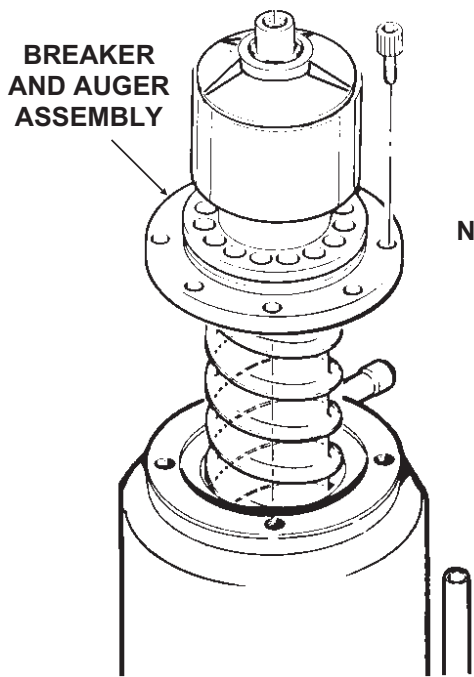

Note: If the auger is stuck, the breaker must be removed from the auger.

The breaker may be removed from the auger and evaporator without disturbing the auger.

- a. Unscrew breaker cover from breaker (left hand threads)
- b. Unscrew auger stud from top of auger.
- c. Unscrew 4 allen head cap screws holding breaker to evaporator.
- d. Lift up & remove breaker from evaporator.
- e. If the auger is stuck use a slide hammer type puller to pull on the auger at the threaded hole. The size of that hole is 5/8"-18.

Inspect the auger, the critical areas of the auger are:

1. The auger body. It should be clean and shining. Sometimes an auger will appear clean when wet, but after it is dry it will be seen to be stained. Scrub the auger with ice machine cleaner and hot water.

Ice machine cleaner is an acid. Handle it with extreme care, keep out of the reach of children.

2. The water seal area. Because the auger has been removed, the water seal will have to be replaced. Remove the water seal top half from the auger, and inspect the auger for minerals. Clean as required.

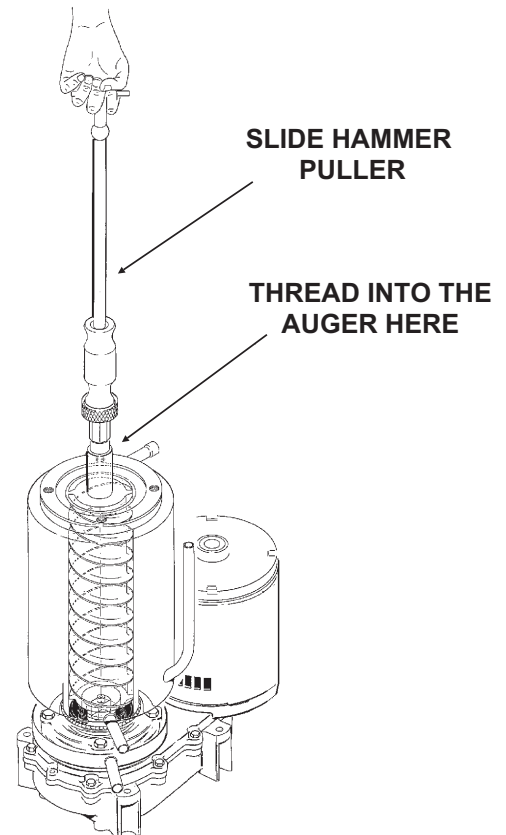

REMOVAL AND REPLACEMENT: Water Seal

To Remove the Water Seal:

(Assuming all steps to remove the auger have been performed.)

1. The gearmotor /evaporator assembly will have to be exposed.
2. Remove the 4 hex head cap screws holding the evaporator to the gearmotor assembly. Lift the evaporator up and off of the gearmotor.
3. Remove the snap ring or wire retainer from the groove under the water seal.

⚠ CAUTION

Sharp Parts Hazard.
Sharp auger edge can cause personal injury. Use gloves when handling auger.

To Replace the Water Seal:

1. Lubricate the water seal with water, and push the water seal into the bottom of the evaporator slightly past the groove for the snap ring.
2. Replace the snap ring and pull the water seal down against it.
3. The part of the water seal that rotates with the auger must also be replaced. Remove the old part from the auger and clean the mounting area.
4. Place a small bead of food grade silastic sealant (such as 732 RTV or Scotsman part number

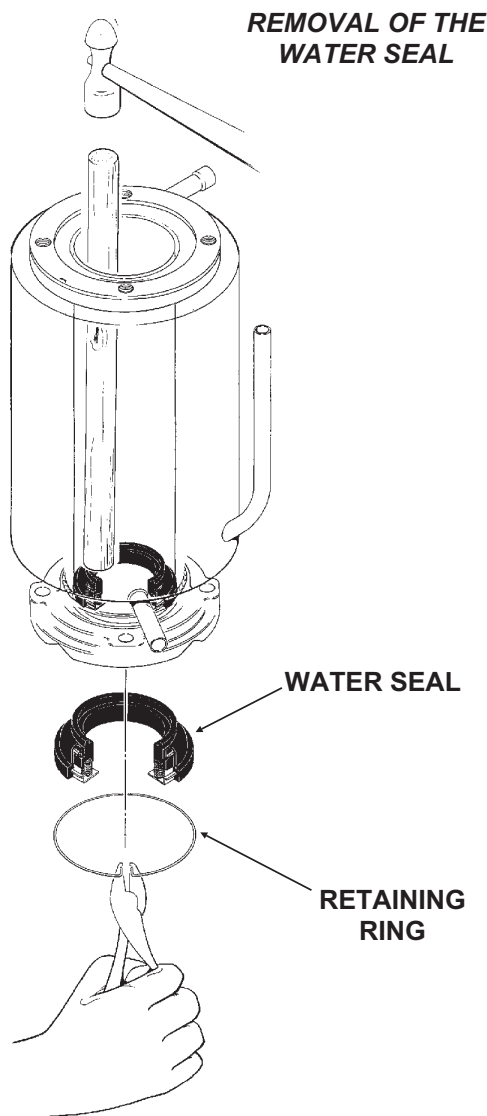

4. Pull or drive out the lower half of the water seal.

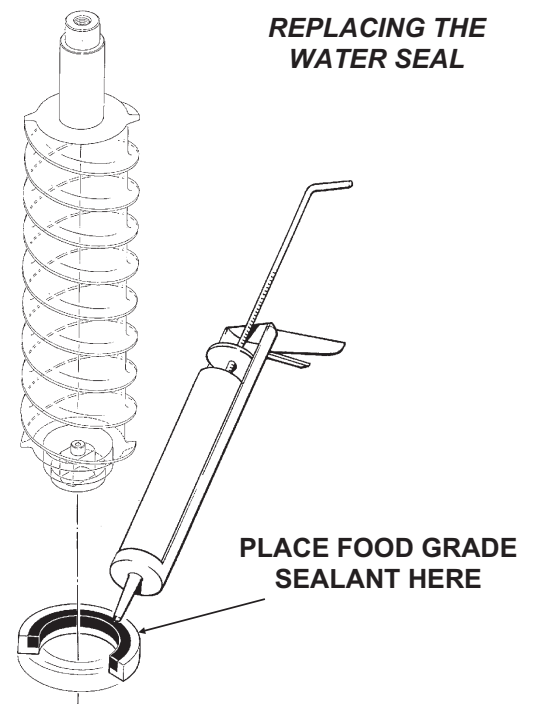

19-0529-01) on the area of the auger where the water seal is to be mounted.

5. Carefully push the water seal (rubber side against the auger shoulder and the silastic) onto the auger.

Do not get any silastic onto the face of the seal.

6. Allow the auger and seal to air dry until the silastic is dry on the surface.
7. If the original water seal was leaking, it would be a good idea to inspect the interior of the gearmotor.

NSE654

REMOVAL AND REPLACEMENT: Evaporator

To Replace the Evaporator:

(Assuming all the steps for removal of the thrust bearing, breaker, auger, and water seal have been performed.)

1. Recover the refrigerant from the ice maker.
2. Unswear the refrigerant connections:
 - a) At the thermostatic expansion valve outlet.

Heat sink the TXV body when unswearing or resweating the adjacent tubing.

b) At the suction line at the joint about 3" from the evaporator.

3. Remove the evaporator.
4. Unswear the drier from the liquid line.
5. After installing a new water seal in the new evaporator (see "To Replace the Water Seal") swear in the new evaporator at the old tubing connections.
6. Install an new drier in the liquid line.
7. Evacuate the system until dehydrated, then weigh in the nameplate charge. Check for leaks.
8. Install auger, breaker, breaker bearing assembly, and ice discharge chute in reverse order of disassembly. See "To Reassemble Evaporator and Auger"

To Reassemble the Evaporator and Auger

1. After the gearmotor has been inspected, fasten the evaporator to the gear motor, be sure that the number of shims indicated on the gear case cover is in place between the gearcase cover and the drip pan gasket. Torque the bolts to 110 inch pounds.
2. Lower the auger into the evaporator barrel, slightly turning it to match up with the drive end. Do Not Drop Into the Evaporator.
3. Complete the reassembly by reversing the disassembly for the breaker & thrust bearing assembly.

REMOVAL AND REPLACEMENT: Evaporator

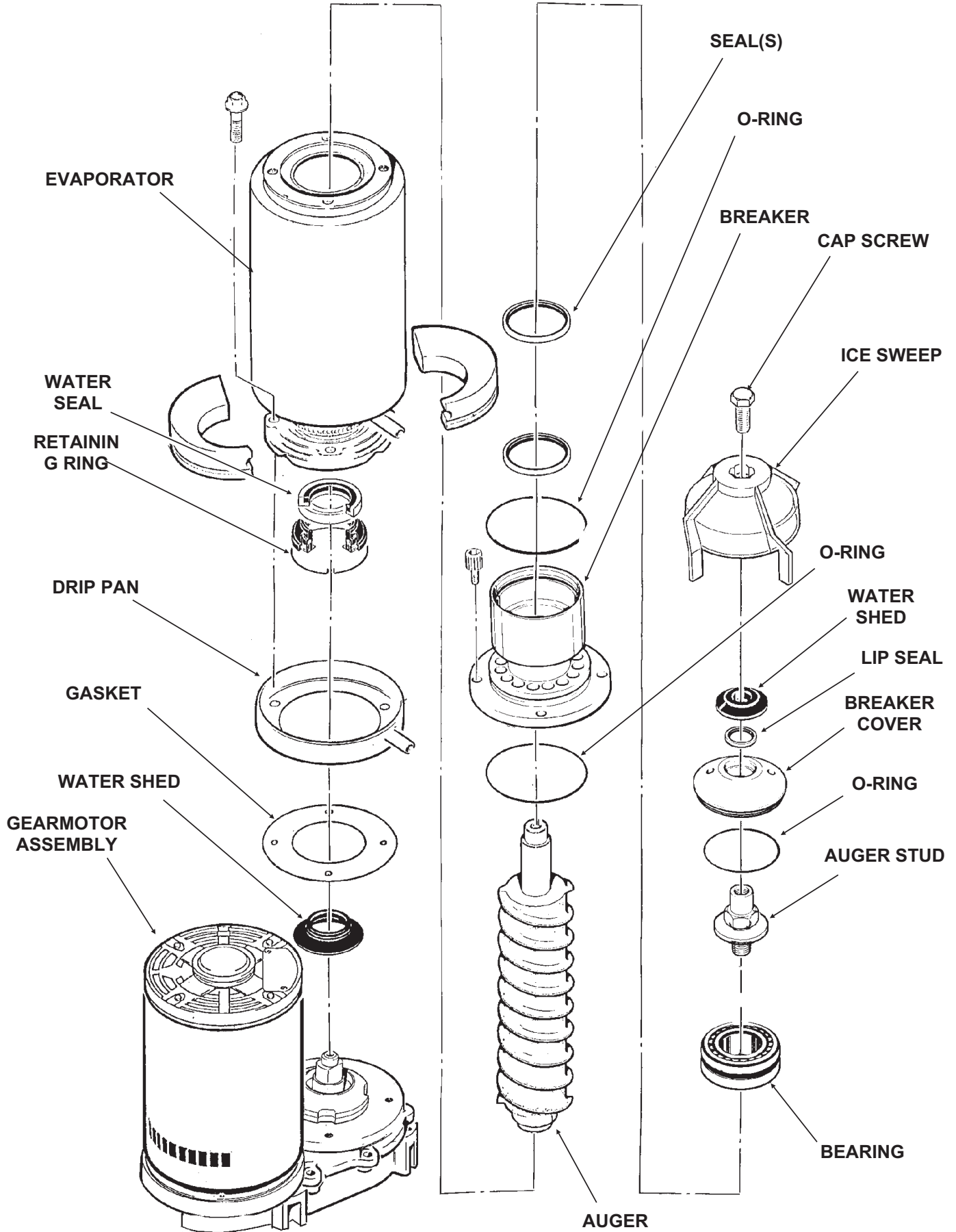

NSE654

REMOVAL AND REPLACEMENT: Gearmotor



⚠ WARNING

Electrical Shock Hazard.
Electrical shock can cause personal injury. Disconnect electrical power before connecting tester.

Note: The gears and bearings are available only as pressed together sets.

D) After replacing parts as required, (if any) reassemble the gearcase. The two smaller gears and the oil should be in the lower case, the output gear will be with the cover. As you lower the cover onto the lower case, the cover will have to be moved closer to the second gear after the output gear has cleared the second gear top bearing.

E) After the case is together, and the locating pins are secure in both ends, replace all cap screws.

To Remove and Repair the Gearmotor Assembly:

(Assuming that the procedures through removal of the water seal have been performed.)

1. Remove the electrical wires from the gear drive motor.
2. Unscrew the 4 cap screws holding the gearmotor to the base of the machine.
3. Remove the gearmotor from the icemaker.

Bench test the gearmotor, check for oil leaks, noise, and amp draw.

To Inspect the gearmotor.

A) Remove the cap screws holding the gearmotor case halves together and pry the two cases apart.

B) To lift off the cover, lift up until you can feel internal contact, then pull the cover towards the output gear end, and then lift the cover (with drive motor attached) up and away from the gear motor case.

Note: The gearcase cover, output gear, bearings and output shaft are a pressed together assembly. Replace as a unit.

C) Inspect the oil, gears, and bearings. If the oil level and condition is acceptable, quickly check the gears and bearings. They are likely to be fine if the oil is.

If there is evidence of water in the oil (rusty bearings and gears; the oil having a creamy white appearance; oil level too high) carefully inspect the bearings and gears. If in doubt about the condition of a part, replace it. The oil quantity is 14 fluid ounces, do not overfill.

Bench test the gearmotor, check for oil leaks, noise, and amp draw.

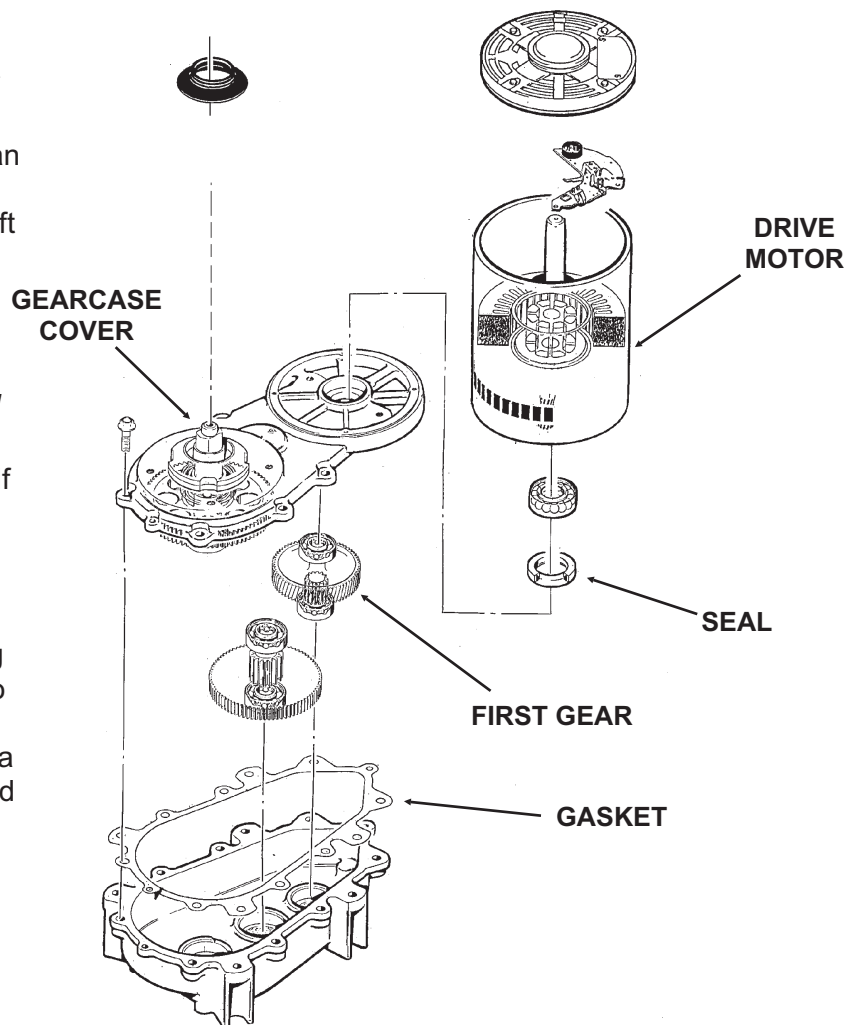

REFRIGERATION SYSTEM SERVICE

General: This ice machine uses R-404A refrigerant and polyolester oil. Do NOT use mineral oil in this refrigeration system.

- When the system is serviced, a special liquid line drier is required. It is included with replacement compressors.
- R-404A is not compatible with mineral oil so these ice machines use Polyolester oil. Polyolester oil absorbs water very easily. A system opened for service must be re-sealed as soon as possible (15 minutes maximum).
- Special leak detection equipment is required to locate small refrigerant leaks. Usually a leak detector capable of detecting a Halogenated refrigerant or HFC-134a will work. Check with the leak detector manufacturer if in doubt.
- Evacuate to 300 microns.
- Liquid charge the system

Access Valves: To use the access valves:

- Remove the cap from the stem, use a 3/16" allen wrench to check that the valve is CLOSED. The remove the core cap.
- Close the valve and replace the caps when done. The valve must be closed and the caps

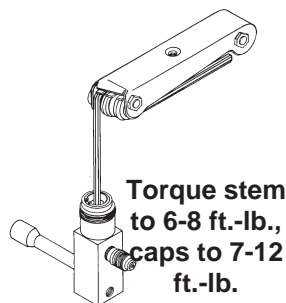

be closed and

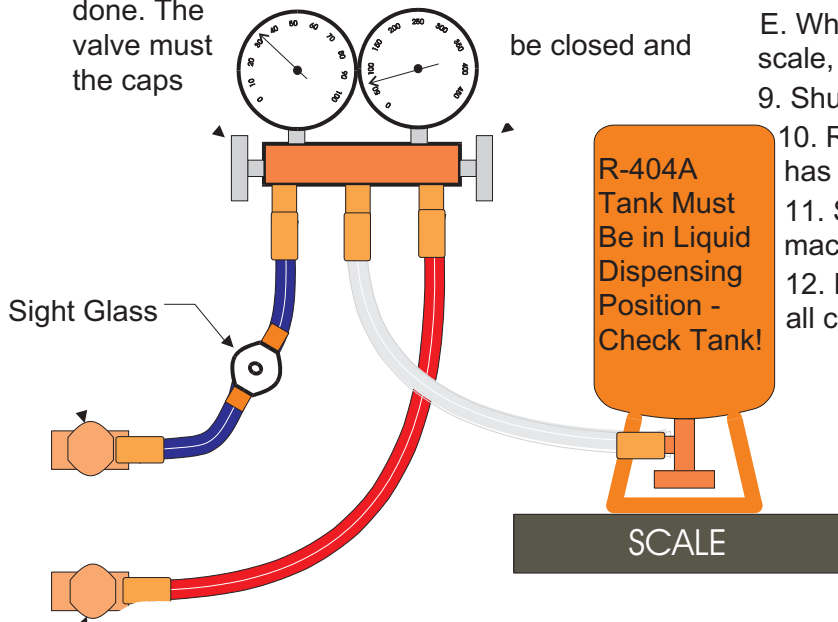

Hose Connection Schematic for Liquid Charging

Instructions for Liquid Charging R-404A

In preparation for charging, the low side hose should have a sight glass, and/or a restricting device (such as a "Charge Faster") installed in it for metering liquid into the low side of the system.

1. After a thorough evacuation shut off the manifold valves and switch off the vacuum pump.
2. Place a drum of R-404A onto an electronic scale.
3. Attach the charging hose to the drum.
4. Open the valve on the drum and purge the charging hose.
5. Zero out the scale.
6. Shut the low side access valve at the ice machine.
7. Open the discharge manifold valve full open.
8. Watch the scale, when the correct charge is shown, shut the manifold valve.

Note: If all of the charge will not "go in" the discharge side:

- A. Shut the discharge access valve at the ice machine.
 - B. Switch the machine on.
 - C. Open the low side access valve at the ice machine.
 - D. Open the low side manifold valve and observe the sight glass to be certain that only gas is flowing into the system.
 - E. When the proper charge is indicated on the scale, shut off the manifold valve(s).
9. Shut off the valve on the refrigerant drum.
 10. Re-open the manifold valves until all liquid has flowed out of the hoses.
 11. Shut the low side access valve on the ice machine.
 12. Remove hoses from ice machine and replace all caps.